

collezione design

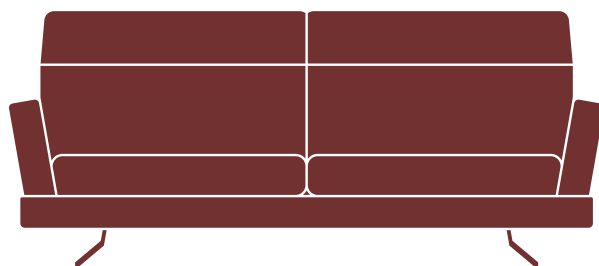

rigosalotti



index

azienda company		divani sofa		complementi complements		tecnica technical	
rigosalotti	04	oceano	14	dulcinea	70	disegni tecnici	168
		airo	26	yoox	76	<i>technical</i>	
		nemo	40	mollis	102	<i>drawings</i>	
		erik	50	loto A	108		
		capohorn	58	vanity	116		
		forum	66	liria	128		
		dominique	78	globe	142		
		paradise	86	cubo	159		
		etoile	104				
		movie	112				
		city	130				
		sintesi	144				
		harlem	154				

azienda
company



salotti made in italy dal 1984
italian upholstered furniture since 1984



Era il 1984 quando ha avuto inizio l'avventura di Rigosalotti nel settore del mobile imbottito, da allora ne abbiamo fatta di strada, ponendoci sempre un passo avanti rispetto alle mode e alle correnti del mercato. L'esperienza di oltre 30 anni di attività nel settore e la capacità di saper combinare artigianalità, design e processi produttivi all'avanguardia, ci consentono ancor oggi di offrire alla clientela prodotti di alta qualità, 100% Made in Italy, capaci di unire funzionalità, estetica e stile. Ecco perché la collezione Rigosalotti si è ampliata nel tempo ed oggi può contare su una serie di divani imbottiti in pelle e tessuto, divani trasformabili prontoletto, letti imbottiti, sedute relax e complementi di arredo.

It was 1984 when Rigosalotti began its adventure in the upholstered furniture industry, we have come a long way since then, always taking a step ahead of market fashions. The experience of over 30 years of activity in the field and the ability to combine craftsmanship, design and latest-generation production processes, allow us to offer customers high quality products, 100% Made in Italy, capable of bringing together functionality, aesthetics appeal and style.

That's why Rigosalotti collection has expanded over time and today includes a series of upholstered leather and fabric sofas, sofa-beds, upholstered beds, relaxing chairs and furnishing accessories.



Materiali d'eccellenza, competenza artigianale e creatività ci guidano quotidianamente nel nostro lavoro. La costante ricerca di soluzioni capaci di coniugare eleganza, funzionalità ed originalità rendono i nostri prodotti protagonisti assoluti dello spazio abitativo. Dalle geometrie più rigorose alle forme più morbide e avvolgenti, ogni soluzione esprime un design unico ed irripetibile, dedicato interamente a garantire al nostro cliente il massimo comfort possibile. Divani, letti e complementi raccontano l'esperienza e lo sviluppo tecnologico che ci accompagnano da oltre 30 anni. L'intero processo produttivo viene gestito internamente, dalla realizzazione delle strutture e imbottiture al taglio e alla cucitura dei rivestimenti, fino all'assemblaggio del prodotto finito. Da sempre puntiamo sulla continua ricerca di soluzioni innovative, sulla formazione e l'aggiornamento dei nostri tecnici specializzati e su una rete commerciale profondamente radicata nel territorio, con l'obiettivo di garantire, accanto alla massima qualità, anche la risposta giusta alle più diverse necessità d'arredo.

Superior quality materials, expert craftsmanship and creativity, guide us in our daily job. The constant search for solutions capable of combining elegance, functionality and originality make our products the absolute protagonists of any living space. Ranging from the strictly geometric to softer and more enveloping shapes, every item presents a unique and exclusive design, entirely dedicated to providing our customers with the greatest possible comfort. These sofas, beds and accessories are testament to the experience and the technological development that have guided us for more than 30 years.

The whole manufacturing process is managed internally, from the construction of the wooden frames and the upholsteries to the cutting and sewing of the covers, up to the assembly of the finished product. We have always focused on the non-stop search for innovative solutions, on the training and updating of our specialized technicians and on a sales network firmly established in the local market, with the aim of ensuring, alongside the highest quality, the right answer to the most demanding furnishing requirements.



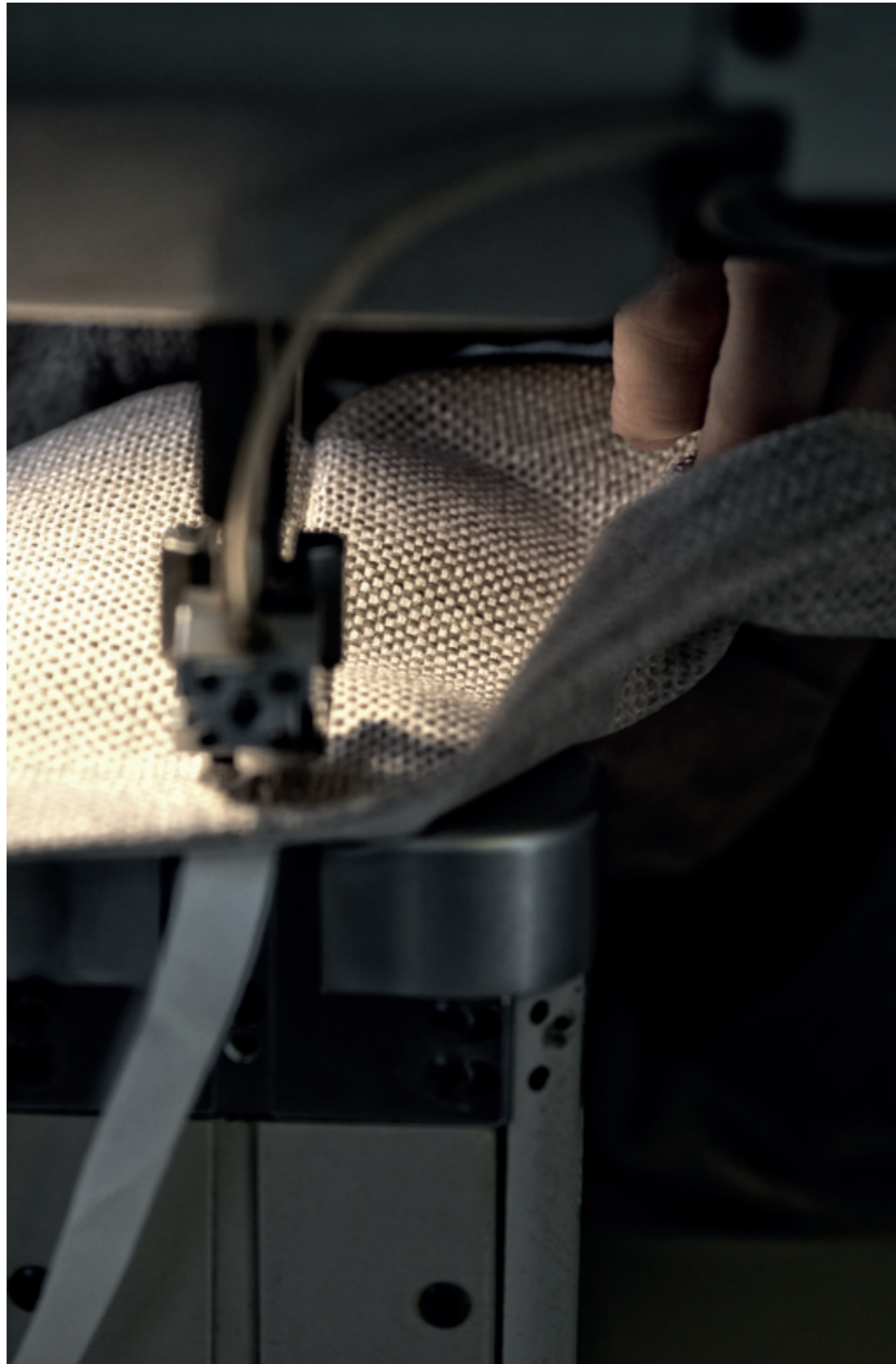

La qualità di un imbottito Rigosalotti è percepibile sin dal primo sguardo: massima solidità grazie alla struttura in legno, tracciabilità dei rivestimenti utilizzati, sedute realizzate con materiali indeformabili accuratamente selezionati. Tutte le nostre creazioni assicurano comodità, durata nel tempo e funzionalità senza confronti.

Rigosalotti upholstery quality is evident at the very first glance: maximum sturdiness thanks to the wooden frame, traceability of the covering materials used in our designs and seats made with carefully selected materials. Our creations guarantee comfort, durability and unrivaled functionality.

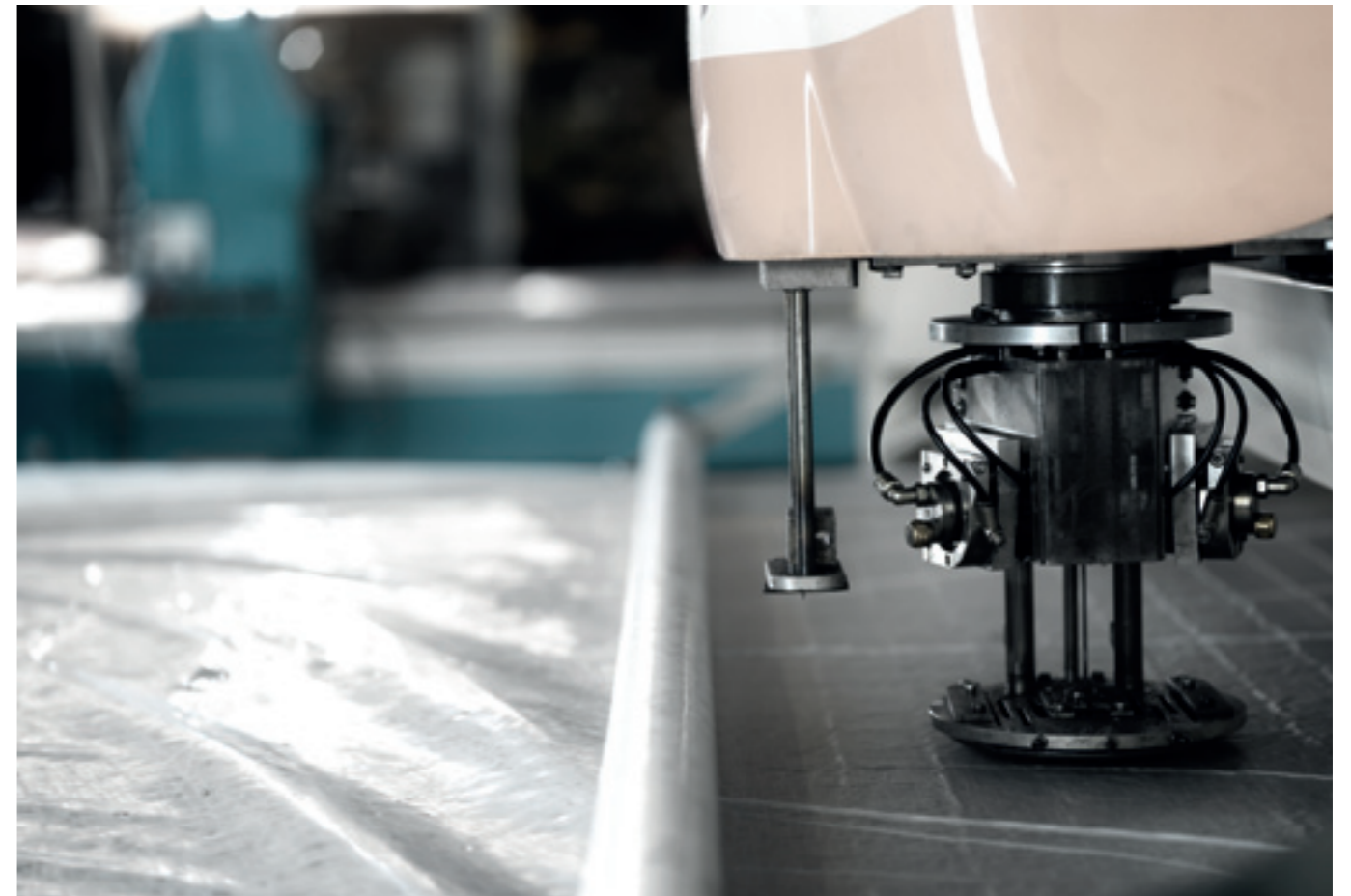

made in italy *made in italy*



Ogni modello Rigosalotti è 100% Made in Italy. Lo stile, l'eleganza e l'originalità del gusto italiano ci guida, da sempre, nella produzione dei nostri imbottiti consentendo di rispondere a qualsiasi esigenza di eleganza e comfort. Tutti i nostri salotti, prodotti interamente all'interno della nostra azienda, utilizzano solamente materiali di prima scelta e di ottima qualità. Il processo produttivo e i materiali, poi, garantiscono elevati standard qualitativi ed il rispetto delle più severe normative internazionali.

Rigosalotti offers 100% Made in Italy upholstered products. The Italian style, elegance and originality has always guided us in the production of our sofas, allowing us to ensure elegance and comfort for any requirement. All our upholstered furniture, produced entirely within our company, use only superior and first quality materials. The production process and the materials, then, guarantee high quality standards and compliance with the strictest international regulations.

garanzia 10 anni *10-year warranty*



Certi della qualità dei materiali utilizzati nei nostri prodotti, ve li garantiamo per 10 anni. La continua ricerca tecnica, l'accurata lavorazione artigianale e il rigoroso controllo di qualità, ci consentono di offrire una garanzia di 10 anni sulle strutture e 5 anni sui meccanismi. La garanzia prevede la riparazione o la sostituzione gratuita del prodotto su difetti accertati.

Due to the quality of the materials we used in our furniture, we guarantee them for 10 years. The continuous technical research, the careful craftsmanship and the strict quality control, allow us to offer a 10-year warranty on the frames and 5 years on the mechanisms. The warranty provides free repair or replacement of the product on established defects.

scheda prodotto *technical sheet*



Ogni prodotto Rigosalotti è corredato da una scheda tecnica nella quale sono indicate il nome del modello, il nome del cliente, il codice del rivestimento, la tipologia di lavaggio, le caratteristiche tecniche dei materiali, le dimensioni, oltre ai moduli e agli optional disponibili.

Rigosalotti provides every product with a technical sheet in which you can find model's name, customer's name, code of the covering, type of washing, technical characteristics of materials and dimensions, as well as units and options available for each model.





divani
sofa

oceano

Oceano è un divano dalla linea essenziale, sobria e geometrica, ma dal carattere deciso. Originale nello stile, grazie soprattutto a seduta e schienale di colore diverso, è la scelta ideale per soluzioni di grande effetto, specie nella versione stand alone. Qui nulla è lasciato al caso: dalle aggraziate staffe in metallo, che quasi lo elevano dall'ambiente circostante, alle eleganti cuciture a contrasto.

Oceano is a sofa with an essential, sober and geometric line as well as a strong character. Its original style, mostly resulted from the different color of the seat and the backrest, makes it the ideal choice for creating highly impressive settings, especially in the freestanding version. Nothing is left to chance: from the graceful metal brackets, which almost elevate it from the ground, to the elegant contrast stitching.





Questo intreccio di dettagli, contrasti e design è il vero leitmotiv di Oceano. Lo si ritrova inalterato nell'elegante lavorazione a trapunta romboidale che ricorda, stilizzandole, le onde del mare e continua nell'inusuale bracciolo strutturato, dalla linea leggermente convessa, che conferisce al divano uno stile insieme minimale e vivace, comunque mai banale.

The interweaving between details, contrasts and design is the leitmotiv of Oceano. This is also evident in the elegant rhomboidal quilting on the backrest that reminds, stylizing them, the sea waves. The leitmotiv continues in the unusual structured armrest, with a slightly convex line, able to give it a minimal and lively, but never trite, style.







Nelle sue molteplici varianti di forma e rivestimento, questo divano mantiene inalterato il suo carattere contemporaneo e schietto. Grazie alla presenza di diversi colori ed elementi (dormeuse, laterali e pouf), Oceano è in grado rispondere a qualsiasi esigenza d'arredo: dagli spazi più piccoli ai loft e saloni, senza mai rinunciare a comodità e stile.

In its many forms and covering, this sofa maintains unaltered its contemporary and pure character. Thanks to the presence of different colors and elements (daybed, side sections and ottoman), Oceano is able to meet any furnishing requirement: from the smallest spaces to lofts and lounges, without compromises on comfort and style.





airo

Airo è un divano concepito con la solidità strutturale e le proporzioni nitide di un'architettura, in cui i volumi importanti e ben definiti vengono sdrammatizzati dai piedini in metallo verniciato. Un sistema dal carattere dinamico nel quale i diversi elementi compongono un originale gioco di morbidi volumi.

Airo is a sofa designed with the structural solidity and the clear proportions of an architecture, in which the metal details de-emphasize the important and well-defined volumes. A dynamic system with different elements able to create an original play of soft volumes.





Caratterizzato da rivestimenti di alta qualità e finiture impeccabili, Airo crea eclettici spazi di convivialità dove trascorrere il tempo libero con gli amici o rilassarsi ascoltando musica.

Characterized by high quality covers and flawless stitching, Airo creates eclectic spaces of conviviality perfect for social gatherings with friends or for listening music in complete relaxation.







Grazie agli elementi angolari, laterali e chaise longue, Airo può essere declinato nelle più diverse combinazioni, sia a parete che a centro stanza, creando sempre spazi equilibrati ed accoglienti. Molteplici anche le varianti colore dei tessuti di rivestimento disponibili.

Thanks to the corner elements, the side sections and the chaise longue, Airo can be adapted to many different arrangements, either against a wall or freestanding, always creating balanced and welcoming spaces. There are also many different colors of fabric covers available.





Forme esili e dettagli in metallo, materiali pregiati e cura per i particolari, leggerezza ed essenzialità nel design. Questo è Airo: un'isola di relax dal concept raffinato e pulito.

Slender lines and metal detailing, precious materials and attention to detail, lightness and simplicity in design. This is Airo: an island of relaxation that is neat and refined in concept.



nemo

Nemo è un moderno sistema di dormeuse modulare, caratterizzato da linee nitide e pulite in cui le finiture sono ridotte ai minimi termini. Ogni dettaglio è studiato per esaltare al massimo la purezza formale e le proporzioni nitide della struttura: dai profili a contrasto ai piedini realizzati in tubo metallico sagomato e verniciato, sino agli schienali, semplici cuscini quadrati o parallelepipedi imbottiti.

Nemo is a modern system of modular daybed, characterized by clear and neat lines in which the finishes are reduced to their bare essentials. Every detail is designed to maximize the formal purity and the clear proportions of the structure: from the contrasting profiles to the shaped and painted metal tube feet, up to the backrests, simple padded square or parallelepiped cushions.







Assolutamente contemporaneo nello stile, questo sistema fa dell'essenzialità il suo punto di forza. Grazie alla seduta unica, senza soluzione di continuità, ai giochi di contrasti tra rivestimento e cuciture, Nemo non passa inosservato.

Absolutely contemporary in style, this system chooses the essentiality as its strong point. And it works, Nemo does not go unnoticed: thanks to the unique continuous seat and the joyful contrasts between covering and stitching, it stand out from the crowd.





Il sistema Nemo è un infinito "domino" di morbidi volumi in cui l'ampia seduta, disponibile in 5 lunghezze (da 160 a 240 cm) e le tre tipologie di schienale, tutte con cuciture e rivestimenti a contrasto, offrono la possibilità di creare divertenti e versatili spazi di convivialità.

Nemo system is like an infinite "domino" made of soft volumes. Its large seats, available in 5 lengths (from 160 to 240 cm) and the three types of backrest with contrasting stitching and coverings, offer the possibility of creating fun and versatile spaces of conviviality.



erik



Dall'abbraccio tra lo stile industriale ed il mondo degli imbottiti nasce Erik, un divano moderno ed elegante dal carattere deciso. L'energia dinamica ed instancabile delle staffe in metallo, che sorreggono i braccioli e la struttura, viene mitigata dalla morbidezza dei cuscini delle sedute e degli schienali.

Erik is the result of the encounter between the popular industrial style and the world of upholstered furniture industry. It's a modern and elegant sofa with a strong character. The dynamic and tireless energy of the metal brackets, which support the armrests and the entire frame, is mitigated by the softness of the seat and backrests' cushions.





Equilibrio, comfort e dettagli sartoriali. Tutto è studiato per creare uno stile sobrio ed elegante senza mai rinunciare, però, alla comodità. Profili a contrasto, morbidezza dei rivestimenti e qualità costruttiva, sono percepibili sin dal primo sguardo.

Balance, comfort and sartorial details. Everything is designed to create a sober and elegant style without compromises on comfort. Contrasting stitching, soft coverings and construction quality, are immediately perceived at the very first glance.





capohorn

Capohorn è un divano dallo stile inconfondibile, caratterizzato da una struttura di sostegno di braccioli e schienali dalle forme affilate, piedini alti in metallo cromato, rivestimenti di pregio ed un originale meccanismo a scatto nel poggiatesta in grado di garantire il massimo comfort.

Capohorn is a sofa with an unmistakable style, characterized by armrests and backsrest frame with angular shapes, high chrome feet, valuable coverings and an original snap mechanism in the headrest able to ensure maximum comfort.





Nella versione con chaise longue, Capohorn esprime al meglio le sue potenzialità: estremamente accogliente e confortevole, grazie alle forme generose, questo divano è in grado di ridisegnare l'ambiente e diventare il fulcro dello spazio abitativo.

This sofa expresses its full potential in the version with chaise longue: extremely cozy and comfortable, thanks to its generous shapes, Capohorn is able to redesign the space and become the crux point of the entire living room.





forum

Le forme lineari, pure, quasi archetipe di Forum disegnano lo spazio dando vita ad un ambiente raffinato e pulito, in grado di rispondere alle esigenze del vivere contemporaneo. Schienali e braccioli realizzati con rivestimenti a contrasto, seguono geometrie semplici e, abbinati ai diversi elementi disponibili (angolari, chaise longue, penisole), danno vita a molteplici soluzioni d'arredo.

The linear, pure, almost archetypal shapes of Forum redesign the space creating a refined and clean setting, able to respond to the needs of contemporary living. Backrests and armrests, with contrasting coverings, follow simple geometries and, combined with the numerous elements available (corner sections, chaise longue, ottoman), make possible several furnishing solutions.

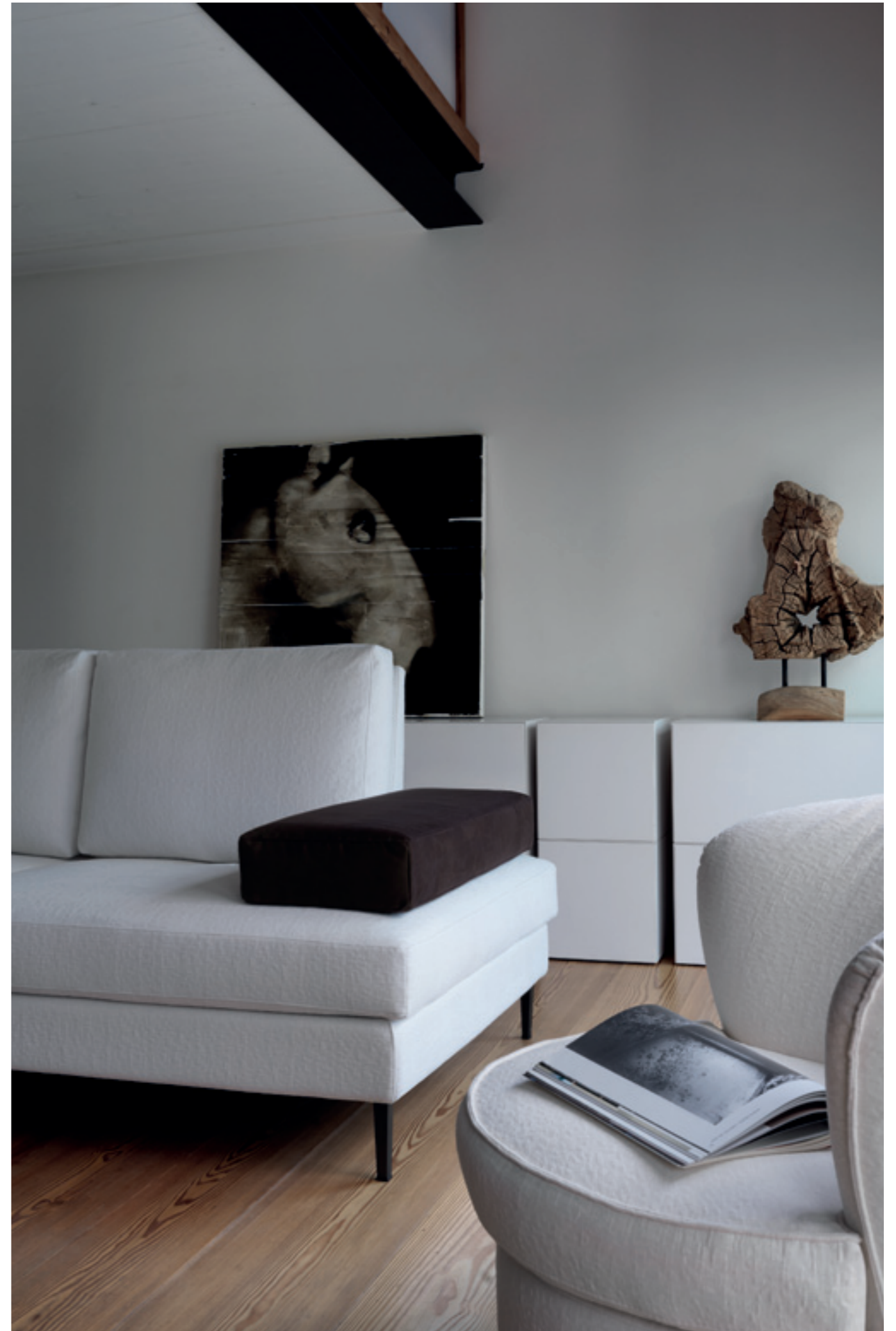



L'estrema flessibilità permette a Forum di adattarsi anche a stili diversi e di poter convivere con elementi d'arredo dal gusto più classico, come la nostra poltrona Dulcinea.

The extreme flexibility of Forum allows it to meet different styles and combine itself with several furnishing elements, even more classic, such as our Dulcinea armchair.

Poltrona Dulcinea

Bellezza essenziale e senza tempo. Sono questi i termini che meglio descrivono Dulcinea: una poltrona dalle forme semplici ed eleganti, quasi archetipe, versatile al punto da essere un vero e proprio jolly, in grado di adattarsi a stili diversi, dal classico al contemporaneo.

Dulcinea armchair

Essential and timeless. These terms best describe Dulcinea: a simple and elegant armchair with almost archetypal shapes, versatile to the point of being a real wildcard, able to adapt itself to different styles and furnishing, both classic and contemporary.







Nella versione con sistema angolare o chaise longue, poi, le forme geometriche di Forum si fanno più complesse. Qui il sistema esprime al meglio la propria versatilità grazie al modulo curvo, in grado di aumentare la superficie d'appoggio, e al pratico meccanismo manuale di regolazione della profondità di seduta che regala un tocco di comfort in più.

The geometric and clear shapes of Forum become more complex in the version with corner sections or chaise longue. Here the sofa shows its own versatility thanks to the curved backrest module, able to increase the support surface, and to the special manual tilting mechanism that allows to adjust the seat's depth giving a touch of unique comfort.



Poltrona Yoox

Yoox è una poltrona confortevole ed elegante dallo stile estremamente rigoroso, in cui le esili staffe metalliche di sostegno donano all'intera struttura, non solo una leggerezza unica, ma anche un tocco di originalità e verve in più.

Yoox armchair

Yoox is a comfortable and elegant armchair with an extremely rigorous style. The slender metal support brackets give to the whole frame, not only a unique lightness, but also a touch of originality and verve.



dominique



Scenografico e di grande impatto, specie nella versione con penisola o elemento angolare, Dominique è caratterizzato da uno stile raffinato e discreto, che gli consente di integrarsi perfettamente in qualsiasi ambiente. Il rigore della struttura, di forma squadrata, viene mitigato dalla morbidezza di schienali e braccioli, con angoli arrotondati, e dalla leggerezza dei piedini in acciaio cromato.

Making a highly dramatic impact, especially in the version with chaise longue or side sections, Dominique has a refined and unobtrusive style, that allow it to suit many different furnishing settings. The austerity of its square shape is de-emphasize by the lightness of the chrome steel feet and by the softness of backseats and armrests with rounded corners.



Dominique, con le sue linee senza tempo, diventa il centro di ogni ambiente, sia esso moderno o classico. Un'isola di comfort dove accogliere gli amici e rilassarsi. Le dimensioni della seduta, infatti, e la presenza nel poggiatesta di un pratico meccanismo manuale per la regolazione indipendente dell'altezza, garantiscono la massima comodità.

Dominique, with its timeless style, becomes the center of every furnishing setting, both modern and classic. An island of comfort where we can rest or welcome friends. The generous size of the seats, indeed, and the presence of a practical manual mechanism in the headrest, for independent height adjustment, guarantee maximum comfort for everyone.





paradise



Protagonista, in questa vera e propria isola flottante di comfort, è l'esile struttura in metallo che abbraccia le sue morbide superfici e la sospende, quasi fosse una nuvola. Paradise è il punto d'incontro tra design, stile e comfort, il luogo dove rigenerarsi dallo stress quotidiano e accogliere gli amici in un'atmosfera di conviviale ed elegante comodità.

The protagonist in this island of comfort is the slender metal structure, that embraces the soft surfaces and suspends it, almost as if it were a cloud. Paradise is the meeting point between design, style and comfort: the ideal place for relaxing and recharging your batteries or welcoming friends in an convivial and elegant atmosphere.



Il raffinato gusto contemporaneo qui può essere toccato con mano, grazie agli accurati dettagli sartoriali e alla grande attenzione estetica del design. Le numerose varianti tessuto a disposizione consentono a Paradise di creare infinite ed armoniche soluzioni d'arredo, anche accompagnandolo alla poltroncina Vanity.

The sophisticated contemporary taste of Paradise can be experienced directly, due to the accurate tailoring details and the great aesthetic attention of the design. The numerous types of fabric available allow us to create infinite and harmonious furnishing solutions as well as matching it with our Vanity armchair.









La sensazione di sognante sospensione e leggerezza raggiunge il suo massimo nella versione Total White in cui non solo il rivestimento, ma anche i piedini sono completamente bianchi. Un comfort totale che viene esaltato anche dall'uso di soffice piuma per le imbottiture di schienali e cuscini.

The sensation of dreamy suspension and lightness reaches the maximum level in the Total White version: not only the covering, but also the sofa feet are completely white. A feeling of total comfort that is also enhanced by the use of soft feather for the padding of backrests and cushions.





Materiali di grande pregio, in infinite combinazioni cromatiche, e dettagli sartoriali, frutto del lavoro instancabile dei nostri artigiani, trovano in Paradise la loro massima espressione.

Highly value materials, several color combinations and tailoring details, resulting from the tireless work of our craftsmen, find their highest expression in Paradise.





Poltrona Mollis

Il morbido profilo di Mollis è un invito ad abbandonarsi al totale relax ascoltando musica o leggendo un buon libro. La sua forma sinuosa e leggera, resa ancora più attraente dai morbidi cuscini con imbottitura in misto piuma in camere separate, si esprime al meglio nella versione chaise longue con l'aggiunta del pouf frontale. Mollis è una poltrona di design studiata per valorizzare il living, completamente sfoderabile, disponibile in diverse varianti di tessuto e colori.

Mollis armchair

Mollis' soft outline is a clear invitation to indulge in total relaxation, listening the music or reading a book. Its sinuous and light shape, made even more attractive by the soft cushions with mixed feather padding in separate rooms, gives its best in the chaise longue version with the addition of the ottoman. Mollis is a design armchair, with a completely removable cover, available in different fabrics and colors, able to enhance every type of living room.



etoile

Stile sobrio e rigoroso per un sistema componibile di grande effetto. Etoile disegna lo spazio con le sue severe forme geometriche che, le cuciture a punto cavallo disponibili a contrasto o in tinta con il rivestimento, sdrammatizzano rendendole in qualche modo più vivaci e giocose.

A sober and rigorous style characterize this highly effective modular system. Etoile draws the space with its severe geometric shapes that the stitching, contrasting or with the same color of the covering, make more lively and playful.







Poltrona Loto A

Serietà, rigore ed essenzialità. Sono questi i termini che meglio descrivono Loto A: una poltrona dalla geometria semplice, quasi archetipa, e dallo stile assolutamente contemporaneo. La forma cubica compatta è resa meno severa dalle staffe in acciaio cromato che le donano una inaspettata leggerezza.

Loto A armchair

Seriousness, strictness and essentiality. These terms better describe this armchair characterized by a simple, almost archetypal geometry and an absolutely contemporary style. The chrome steel brackets offer an unexpected lightness to the compact cubic shape of Loto A.

Il rigore formale, il savoir-faire ed i materiali di pregio si incontrano per dar vita ad un divano dal design elegante ed essenziale, perfetta sintesi di comfort e robustezza. Le lunghe ed esili staffe in metallo cromato, il pregio dei rivestimenti completamente sfoderabili, la cura sartoriale delle cuciture, tutto parla di qualità. Un livello qualitativo elevato che si ritrova inalterato nella poltrona Loto A, compagno perfetto per Etoile.

Accuracy, know-how and precious materials has combined here to create a sofa with an elegant and essential design, a perfect synthesis of comfort and robustness. Its superior quality is clear in every details: the long and slim chrome metal brackets, the quality of the covers (completely removable) and the sartorial stitching made with great care. A high quality level that is unchanged also in Loto A armchair, the perfect companion of Etoile.





movie



Movie è un divano componibile, moderno e ricercato, caratterizzato da profonde ed accoglienti sedute, finiture a contrasto ed originali piedini in acciaio cromato. Un sistema in grado di abbinare in maniera impeccabile comfort e stile, dando vita ad un design eclettico che gli consente un'armonica collocazione in qualsiasi contesto d'arredo.

Movie is a modular sofa, modern and sophisticated, characterized by deep and cozy seats, contrasting finishes and original chromed steel feet. A system that perfectly combines comfort and style, creating an eclectic, but also harmonious, design ideal for any furnishing context.





Poltrona Vanity

Vanity è una poltrona dallo stile contemporaneo e sobrio, caratterizzata da un'ampia e confortevole seduta in materiale indeformabile. Le sue forme nitide ed essenziali sono rese più vivaci dalla struttura metallica verniciata e dagli inserti di tessuto sui braccioli, dello stesso tono del resto della poltrona. La grande varietà cromatica dei rivestimenti e della struttura metallica, consentono a Vanity di essere il complemento perfetto per ogni arredo.

Vanity armchair

Vanity is an armchair with a contemporary and sober style, characterized by a large and comfortable seat made of crushproof material. The clear and essential shape is enhanced by the painted metal framework and the colored fabric inserts on the armrests. Vanity is the perfect complement for every piece of furniture due to the great chromatic variety of the coverings and the metal framework.







Nella versione con penisola, Movie esprime il meglio di sé grazie anche al meccanismo basculante indipendente, che permette di regolare la profondità della singola seduta consentendo ad ognuno il massimo della comodità.

Movie excels in the peninsula version, thanks to the independent tilting mechanism which allows to adjust the depth of the single seat, enabling maximum comfort for each individual.





Grande flessibilità anche delle finiture. Nella versione Total White lo stile ricercato di Movie raggiunge il suo apice esaltandone l'eccellenza dei materiali e la grande cura dei particolari. Come il basamento aereo con i piedi in finitura cromo, in grado di conferirgli una grande personalità.

Movie flexibility is also confirmed by the wide availability of covers. The sophisticated style, indeed, reaches its peak in the Total White version, enhancing the excellence of the materials and the great attention to the details. Such as the airy framework with chrome feet, able to give it a great personality.





Ricercatezza nella soluzioni di design, sapienza nella scelta dei materiali e grande attenzione ai dettagli, sono gli elementi chiave di questo sistema componibile. Una scelta di stile che lo rende un divano estremamente versatile e perciò ideale per dare un tocco di eleganza e carattere a qualsiasi salotto.

The key elements of this modular system are the refinement in the design solutions, the wisdom in the choice of materials and the great attention to the details. A choice of style that makes it an extremely versatile sofa, perfect for adding a touch of elegance and character to any living room.



Poltrona Liria

Liria è la versione 4.0 della classica poltrona da lettura che qui, sotto le sapienti mani dei nostri artigiani, viene alleggerita e rivisitata grazie all'introduzione di svettanti piedini in metallo. Le linee arrotondate si fanno ancora più avvolgenti e sinuose, mentre il materiale di pregio del rivestimento, la trasforma nel punto focale sia di ambienti classici che moderni.

Liria armchair

Liria is the 4.0 version of the classic reading chair that here, under the expert hands of our craftsmen, it's lightened and revisited due to the introduction of slender metal feet. The traditional rounded lines became even more enveloping and sinuous, while the precious material of the covering has transformed it into the focal point of both classic and modern setting.

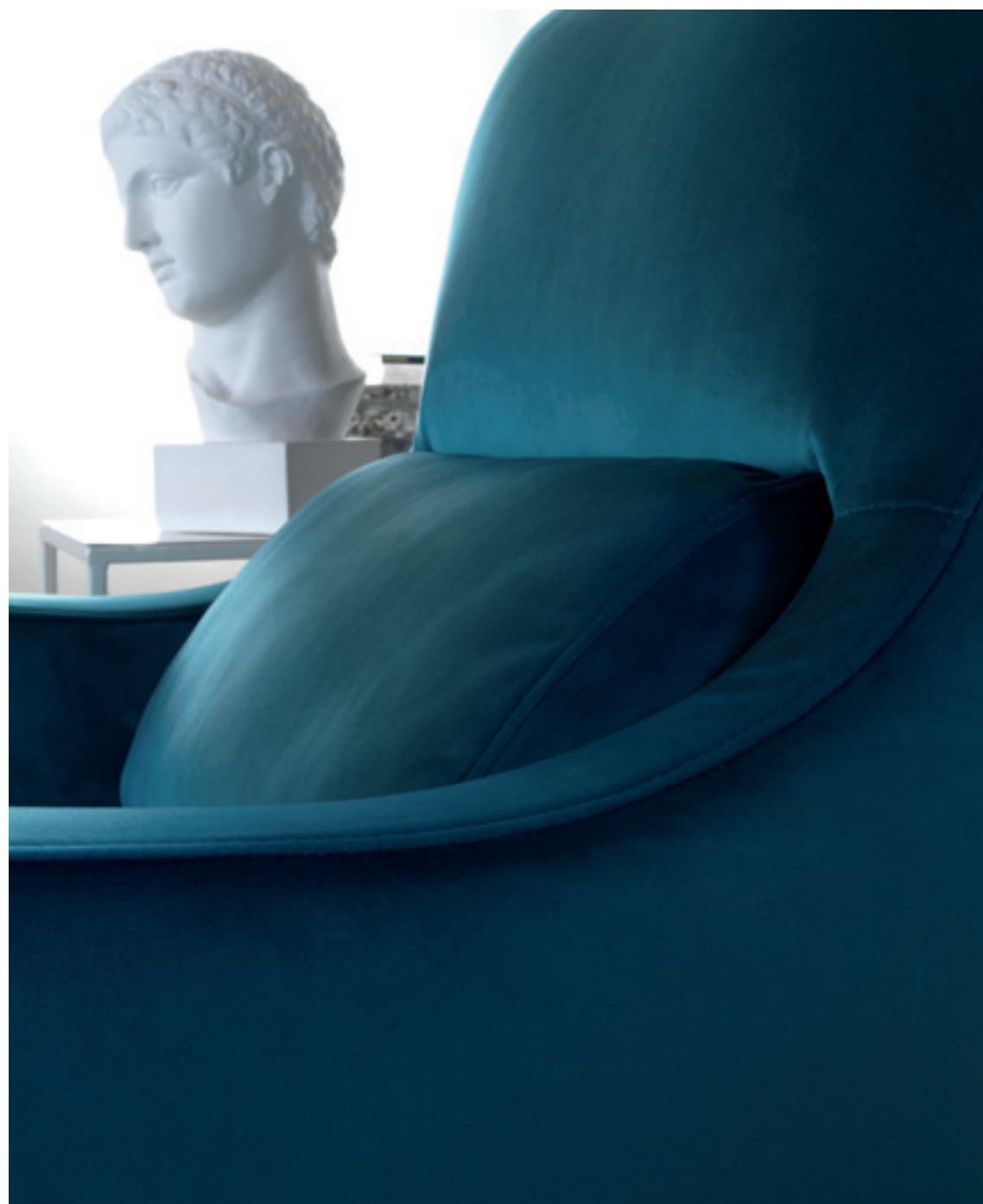

city



Elegante e ricercato, City riduce ai minimi termini qualsiasi elemento superfluo offrendo uno stile leggiadro e sofisticato. Un divano dal look contemporaneo, quasi sospeso a mezz'aria grazie ai piedini cromati dal tratto essenziale ma deciso (in due versioni), con una seduta profonda e accogliente che sembra quasi proseguire senza soluzione di continuità nell'ampio bracciolo.

Elegant and sophisticated, City minimizes any superfluous element, offering a graceful and exclusive style. A sofa with a contemporary look, almost suspended in mid-air thanks to the essential but also decisive chrome feet (available in two versions), with a generous and cozy seat which it seems to continue in the wide armrest.





La linearità razionale e dinamica della struttura, esaltata al massimo nella versione stand alone, convive con l'accogliente morbidezza dei cuscini e dei rivestimenti, completamente sfoderabili, per garantire il massimo relax in ogni momento del giorno.

The frame's rational and dynamic linearity, enhanced in the freestanding version, coexists with the cozy softness of the cushions and covers (completely removable) to ensure the maximum relaxation at any time of the day.



Un sistema componibile che offre infinite combinazioni, grazie ai suoi numerosi elementi modulari (sedute, dormeuse, angoli, isola e pouf) e ai rivestimenti disponibili. Pienamente soddisfatte anche le diverse esigenze di postura, attraverso il semplice meccanismo basculante che consente di variare la profondità delle sedute.

It's a modular system that offers endless combinations, due to its numerous elements (fixed sofas, daybed, side sections, island and ottoman) and covers. Moreover, it has a special tilting mechanism, that makes possible to adjust the seat depth, satisfying different posture requirements.





Studiato per garantire il massimo della funzionalità anche l'elemento angolare, in cui le geometrie razionali vengono addolcite dai moduli curvi che ne aumentano anche la superficie d'appoggio.

The corner units is designed to ensure maximum comfort and functionality: the geometric shape, indeed, is softened by the curved modules that, in addition, extend the support area.





Poltrona Globe

In pelle o tessuto non sfoderabili, questa poltrona dal design unico ed inconfondibile è caratterizzato da una struttura in metallo schiumato a freddo e scocca dalla forma avvolgente, oltre che da un sistema girevole e basculante in grado di assicurare il massimo comfort di seduta.

Globe armchair

Available in both non-removable leather and fabric, this armchair has an unique and unmistakable design. It's characterized by a cold-foamed metal structure and a wraparound shell, as well as a revolving and tilting system that ensures maximum seating comfort.



sintesi

Sintesi è un sistema componibile che, grazie all'alternanza di sedute, penisole, dormeuse e pouf, crea accoglienti isole domestiche nelle quali vivere il proprio tempo libero in assoluto relax.

This is a modular system with a lot of elements available (fixed sofa, chaise longue, daybed and ottoman) that create a cozy domestic island in which it's a pleasure spending free time in absolute relaxation.







Un divano che supera il tradizionale concetto di comfort: semplicità formale e pulizia estetica si uniscono per dar vita a forme armoniche, accoglienti e funzionali in perfetto equilibrio tra eleganza, creatività e praticità.

This is a sofa that exceeds the traditional concept of comfort. Formal simplicity and aesthetic cleanness interact to create harmonious, welcoming and functional shapes in perfect balance between elegance, creativity and functionality.







harlem

Un vero e proprio classico del design contemporaneo in cui gli elementi morbidi di sedute e schienali fanno da contrappunto alle rigorose geometrie della struttura. L'eleganza e la robustezza, la solidità e la classe di questo divano, abbinati a finiture e tessuti di grande qualità, donano fascino e carattere ad ogni ambiente.

It's a true classic of contemporary design in which the soft elements of seats and backrests act as a counterpoint to the rigorous geometry of the frame. The elegance and the sturdiness, the solidity and the style of this sofa, combined with the high quality of finishes and fabrics, give charm and character to every space.







L'attenzione artigianale emerge anche nei piccoli dettagli, come i piedini in rovere moro con profilo cromato o interamente in acciaio cromato, il reggischienale in metallo di serie o la grande varietà di rivestimenti disponibili in numerose varianti colore, sia in tessuto che in ecopelle.

The artisan attention and care emerge especially in the small details, such as the feet in chrome steel or chrome-trimmed dark oak, the standard chrome backrest support or the wide variety of covering available, both in fabric and eco-leather.

Pouf Cubo

Grazie alle sue forme essenziali e geometriche, Cubo è un vero e proprio jolly in grado di integrarsi perfettamente in ogni tipo di salotto. Non solo è in grado di offrire un'utile area di appoggio ma, grazie ai rivestimenti in tessuto nei colori più trendy, anche di aggiungere un tocco di stile e originalità ad ambienti altrimenti anonimi.

Cubo ottoman

Thanks to its essential and geometric shapes, Cubo is a wildcard able to integrate itself in any type of living room. Not only is it able to offer a useful support area but, thanks to the countless trendy colors of covers available, it also adds a touch of style and originality to otherwise anonymous environments.







Nella versione con penisola panoramica o dormeuse, Harlem diventa il fulcro della zona relax, grazie a sedute generose e confortevoli, realizzate in poliuretano espanso indeformabile, e a schienali con cuscini bifacciali in misto piuma. Il massimo della comodità in un divano impeccabile e senza tempo.

Harlem becomes the center of the relaxation area especially in the version with panoramic chaise longue or daybed, thanks to generous and comfortable seats, made of crushproof polyurethane foam, and the backrests with bifacial cushions in mixed feather. An impeccable and timeless sofa able to offer maximum comfort.





tecnica
technical

airo

divani fissi
fixed sofas

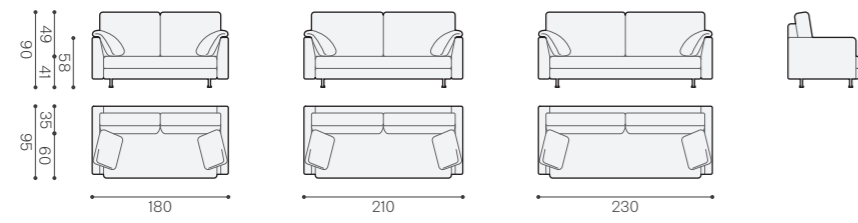

elementi laterali
side sections

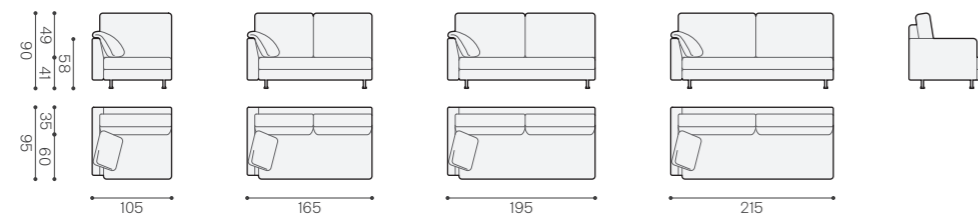

elementi centrali
central sections

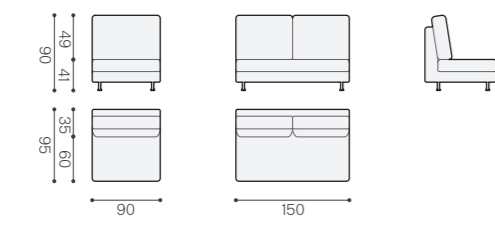

angolo aperto
open corner

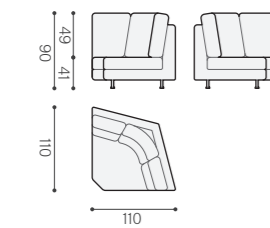

angolo con laterale
corner with side unit

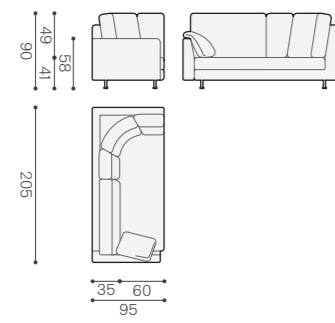

angolo con centrale
corner with central unit

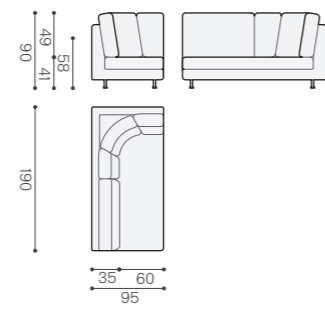

penisola
chaise lounge

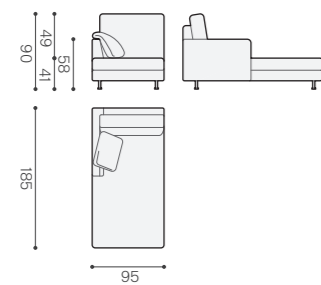

pouf
ottoman

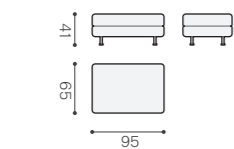

capohorn

divani fissi
fixed sofas

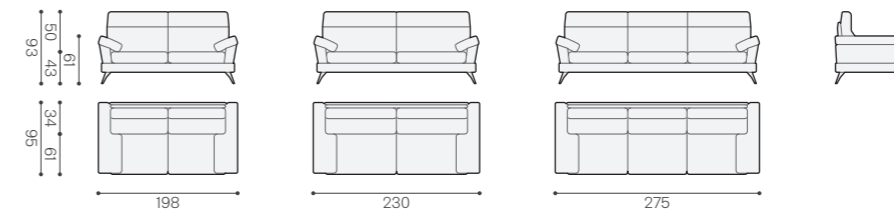

elementi laterali
side sections

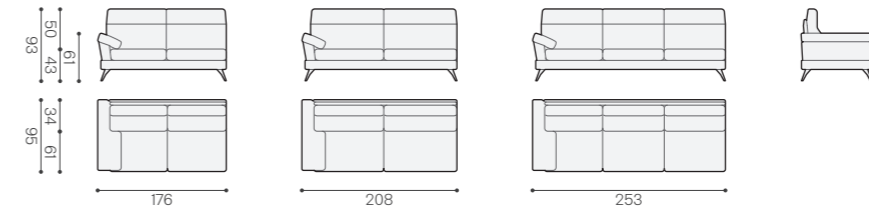

penisola
chaise longue

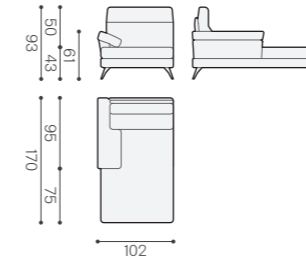

dormeuse
daybed

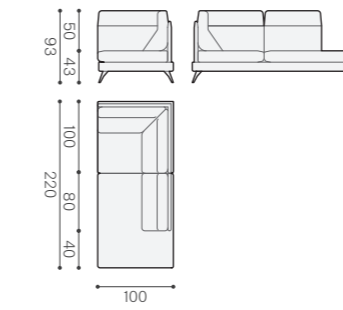

city

divani fissi
fixed sofas

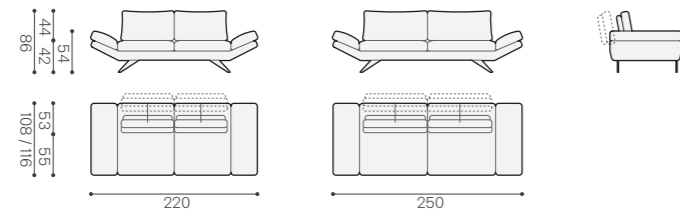

elementi laterali
side sections

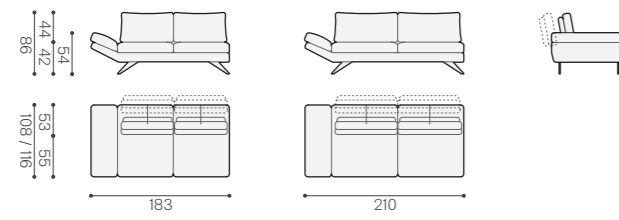

angolo chiuso
closed corner

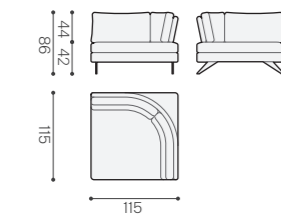

isola
island unit with
terminal

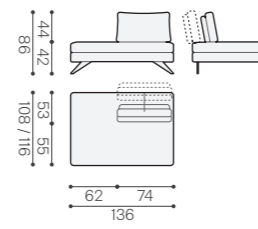

dormeuse
daybed

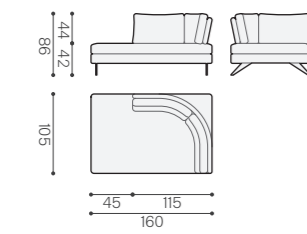

pouf
ottoman

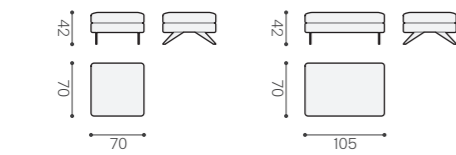

dominique

divani fissi
fixed sofas

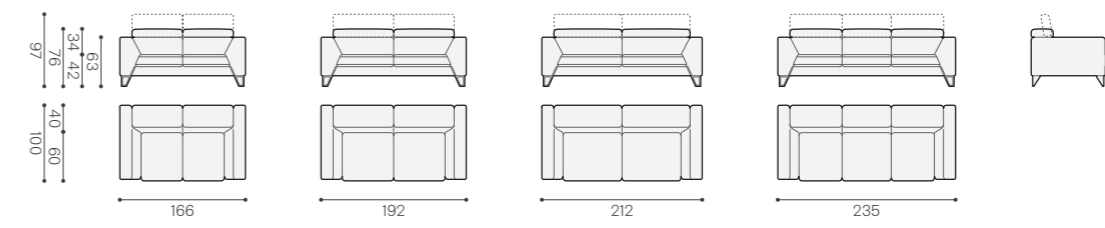

elementi laterali
side sections

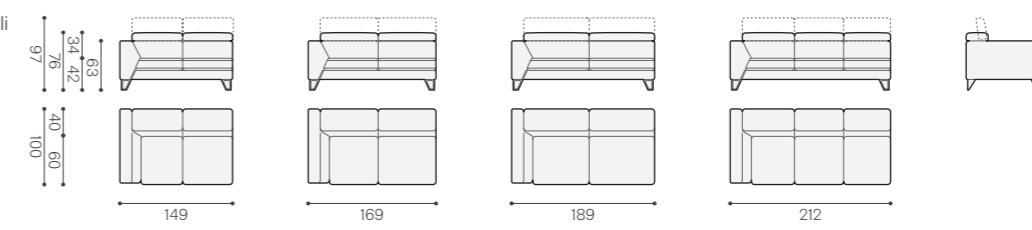

penisola
chaise longue

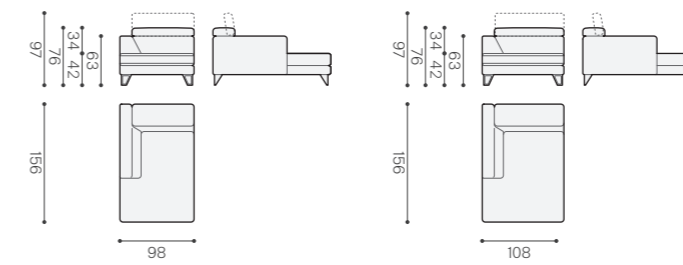

dormeuse
daybed

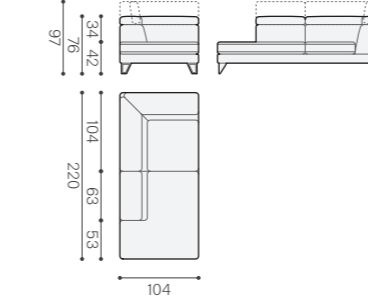

pouf
ottoman

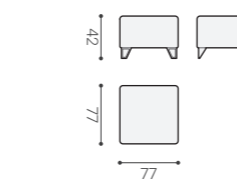

erik

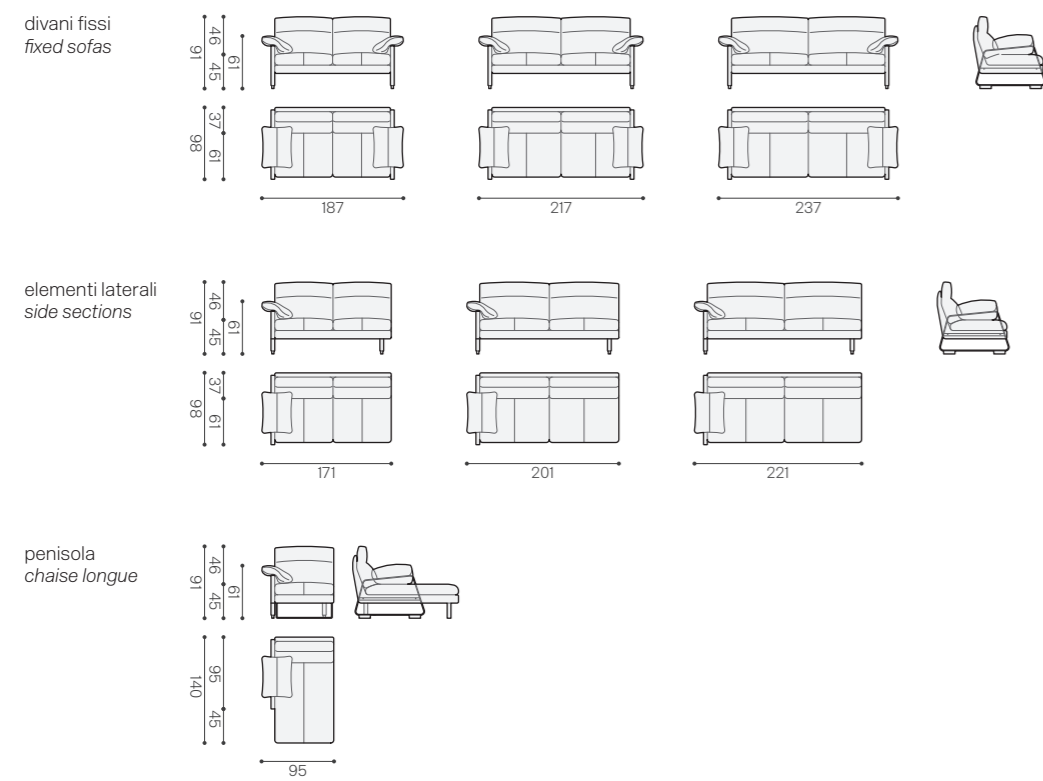

etoile

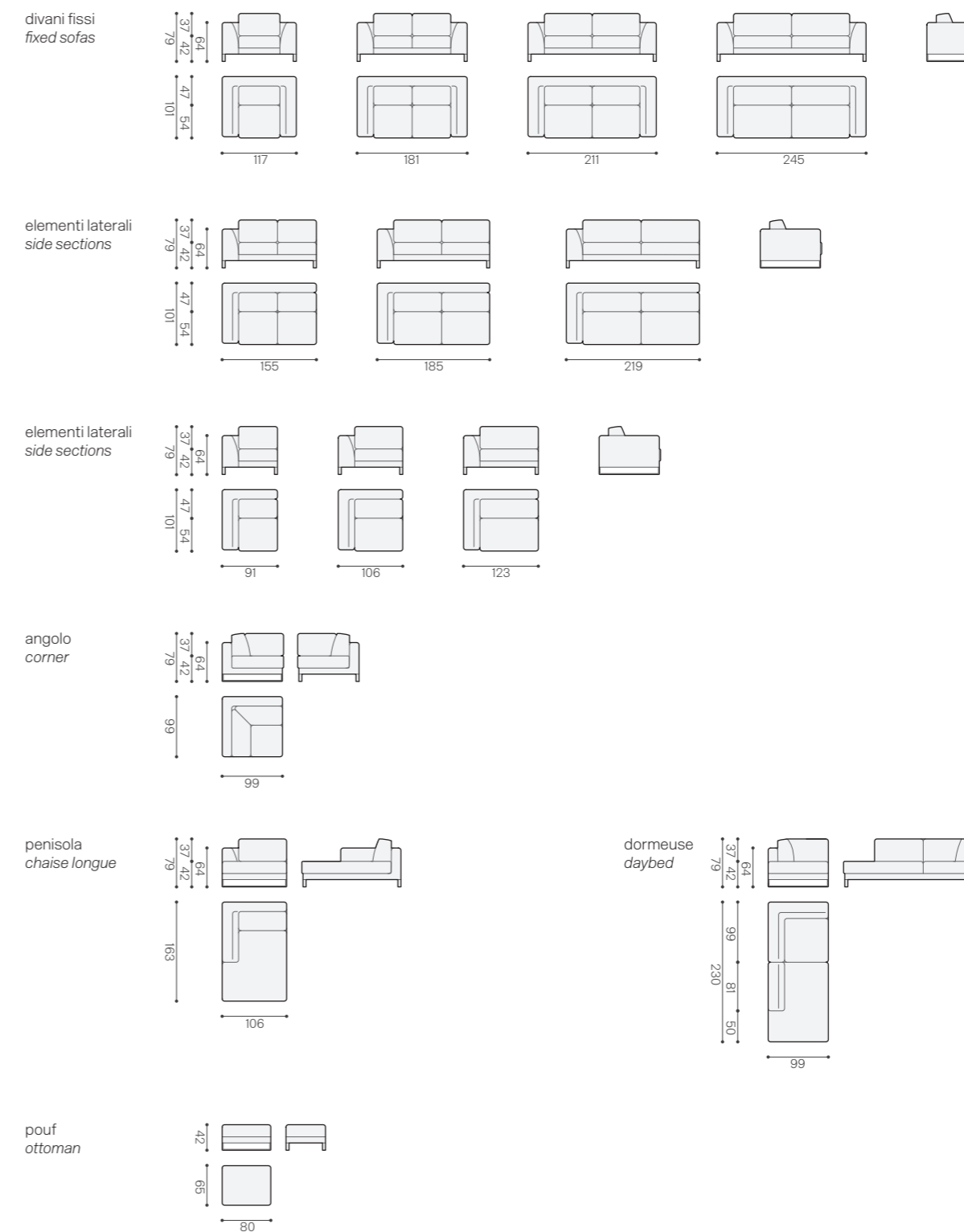

forum

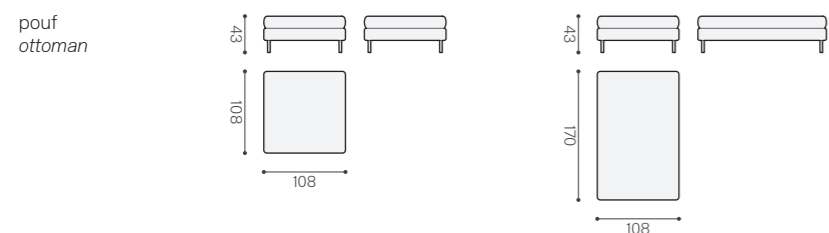
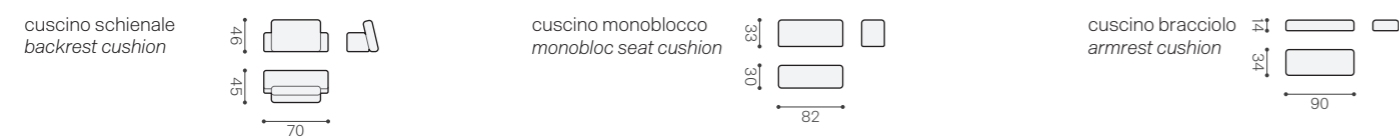
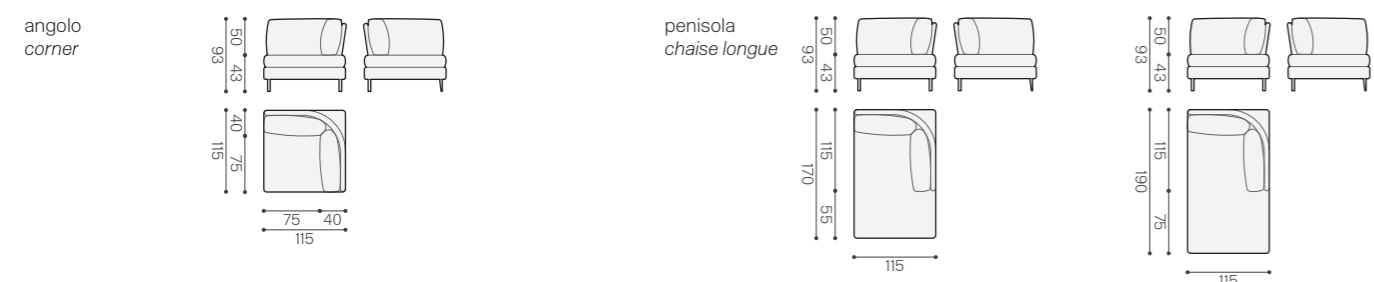
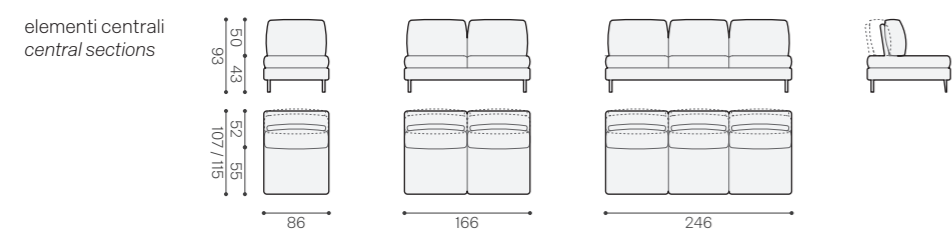
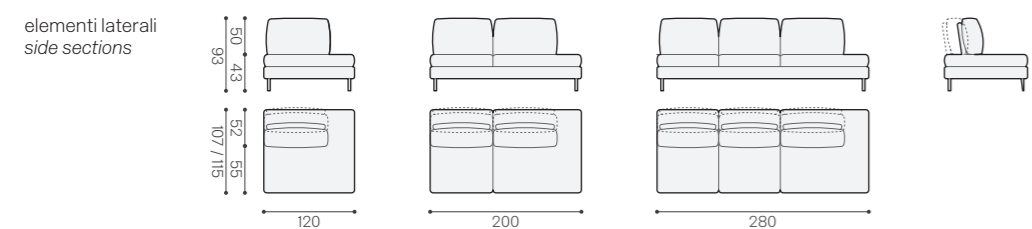
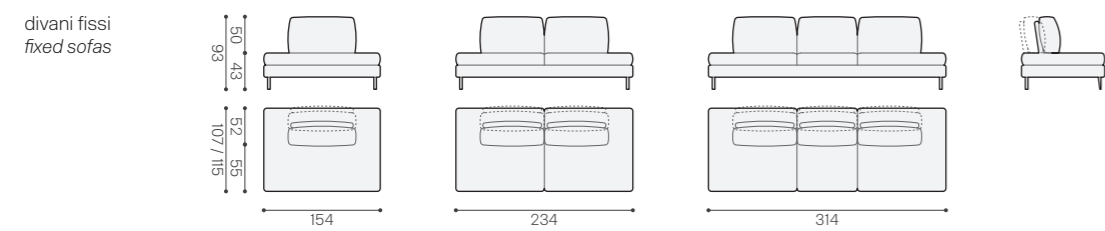

harlem

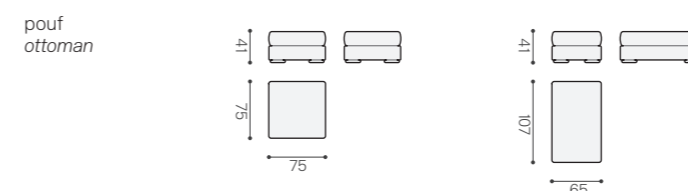
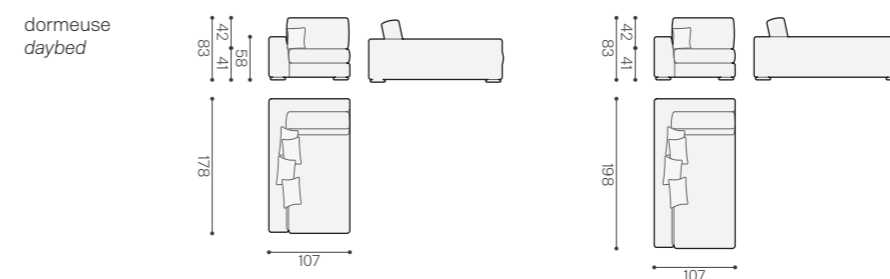
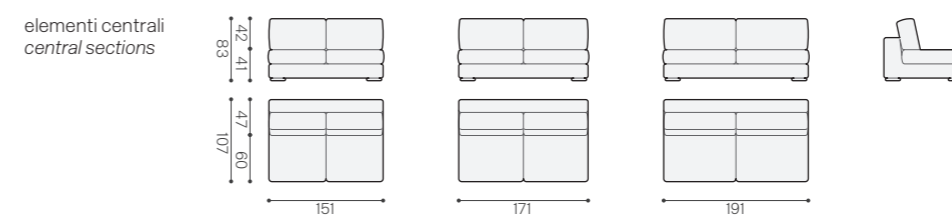
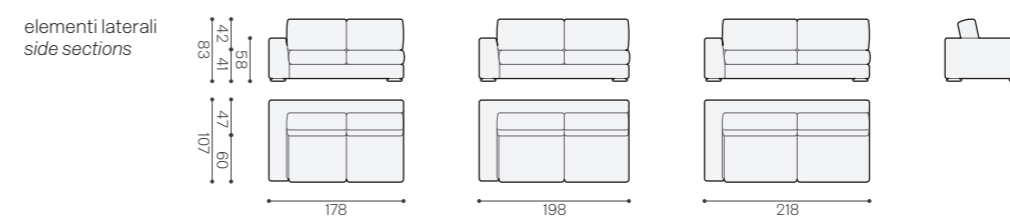
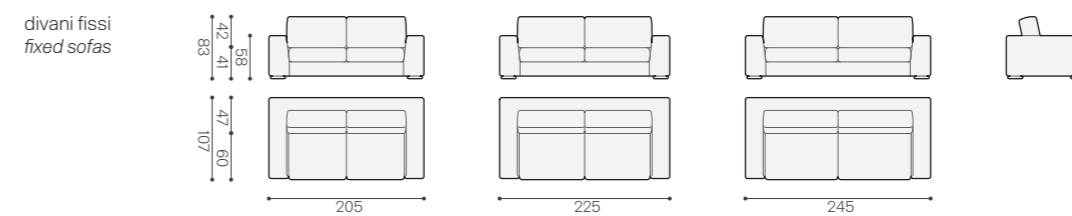

movie

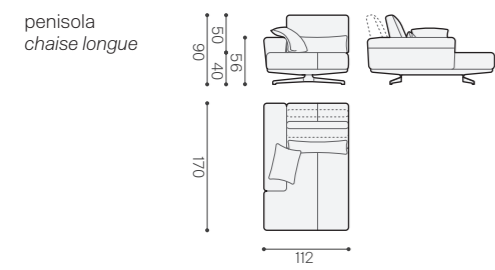
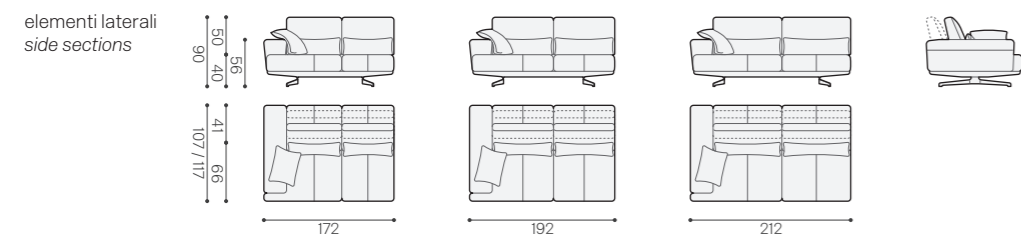
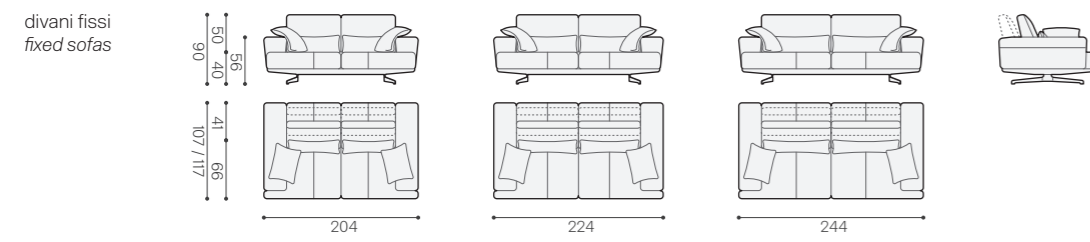

nemo

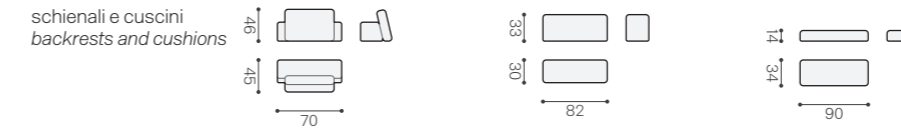
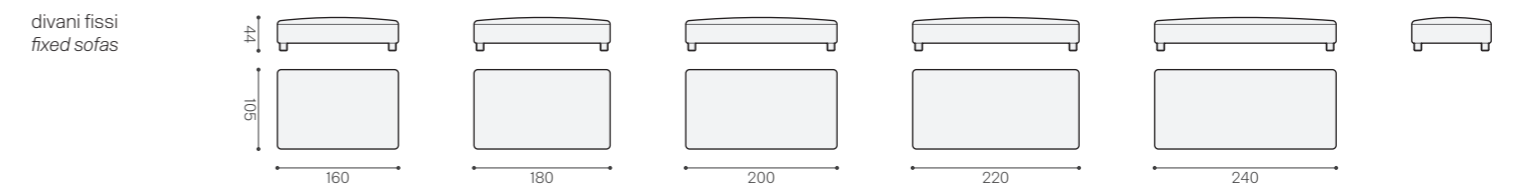

oceano

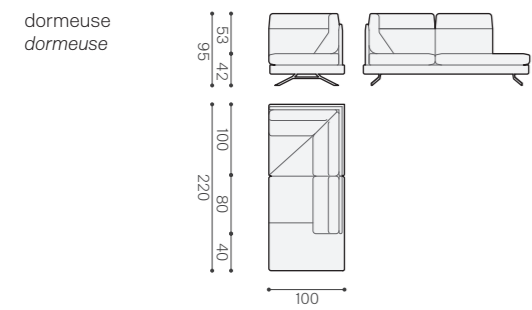
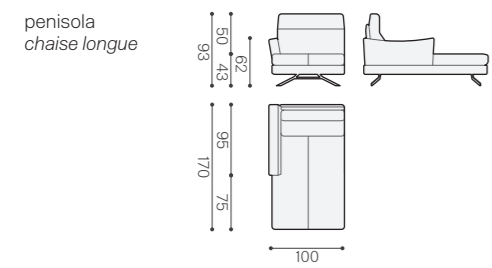
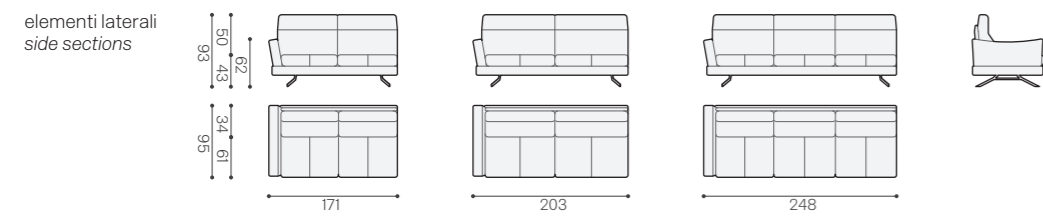
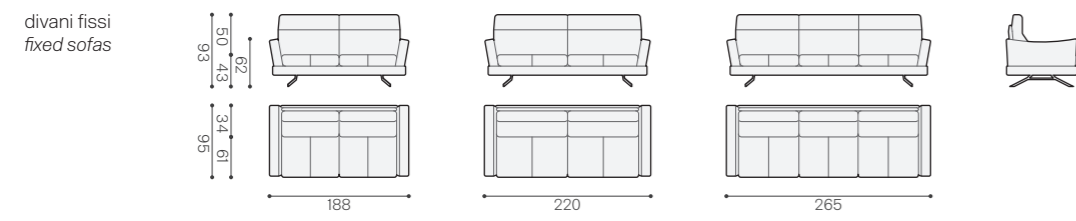

paradise

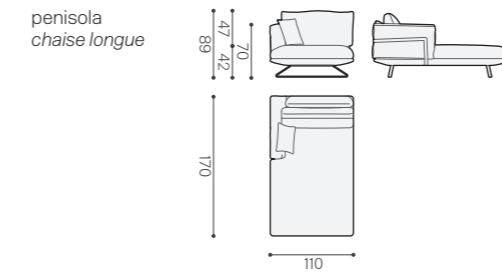
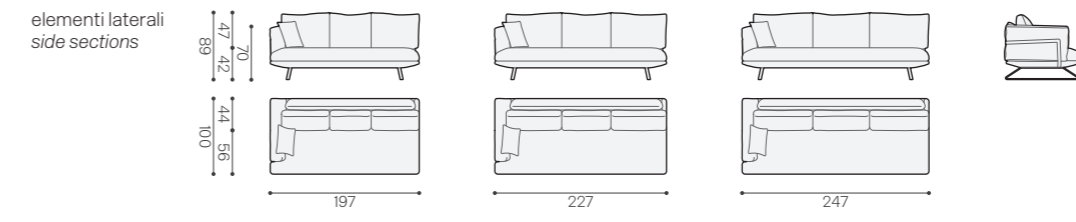
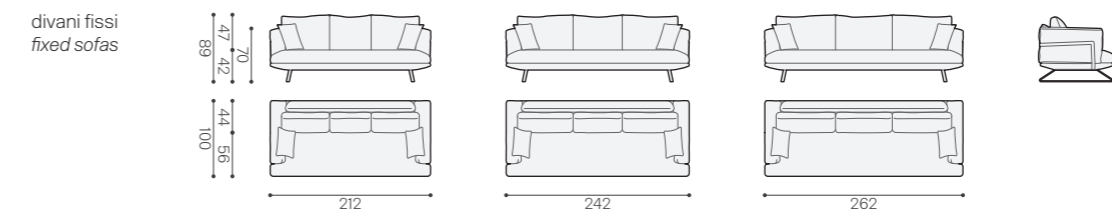

sintesi

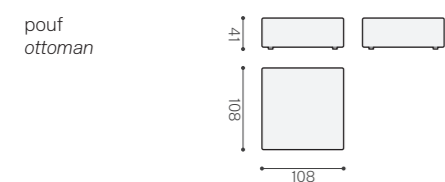
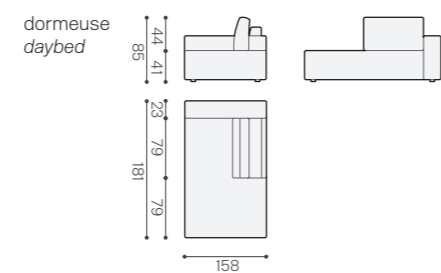
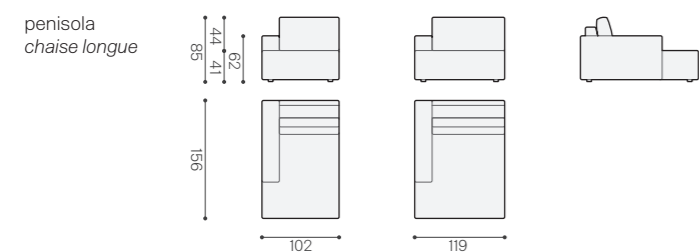
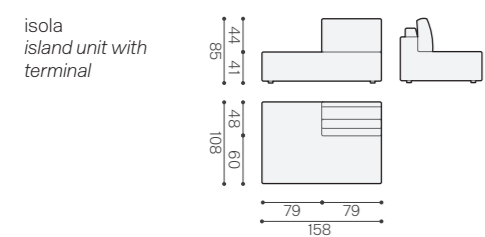
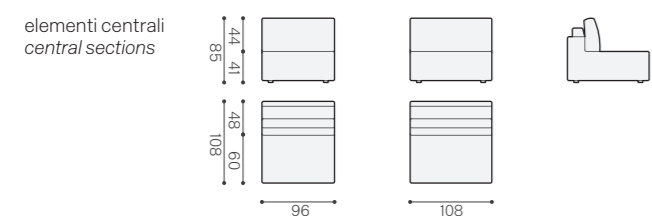
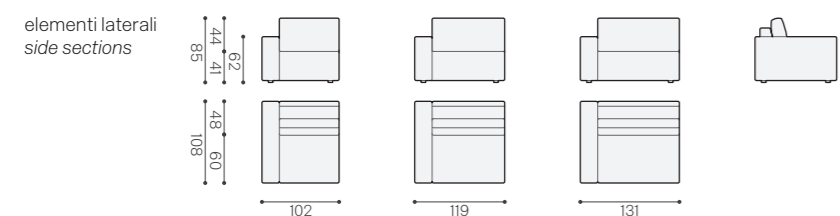
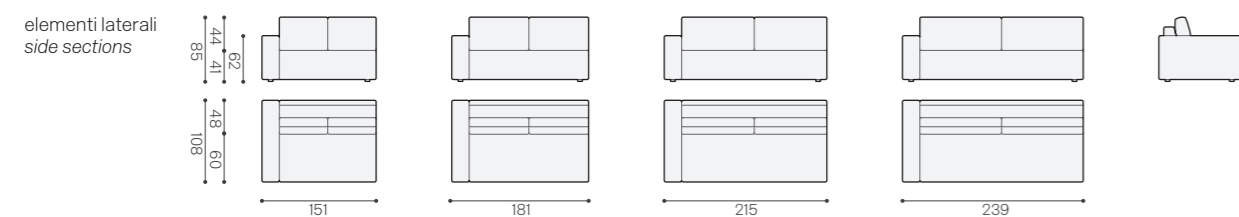
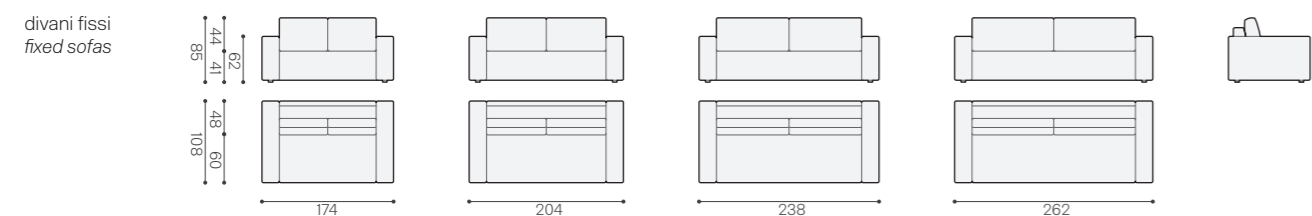

cubo

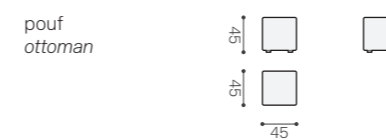

dulcinea

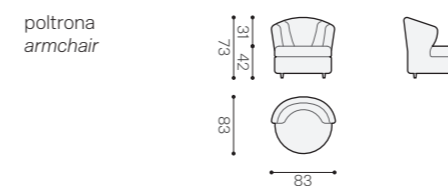

globe

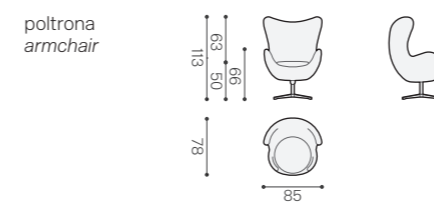

Ioto A

poltrona
armchair

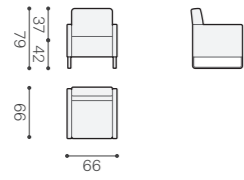

liria

poltrona
armchair

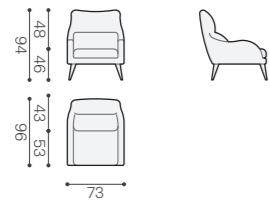

mollis

poltrona
armchair

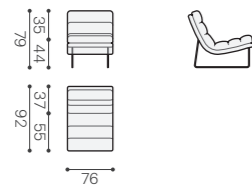

pouf
ottoman

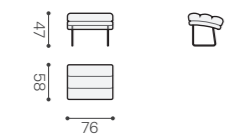

vanity

poltrona
armchair

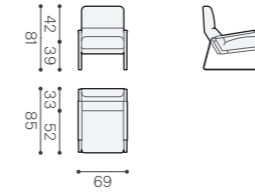

yoox

poltrona
armchair

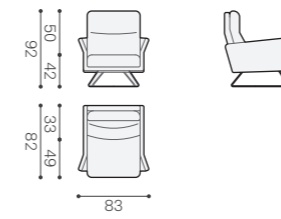

Graphic Design
grucciadesign.

Photo
Studio Emozioni

Styling
Luigina Pilloni

Pre-Press
Studio Emozioni

Printing
Imoco Spa

Rigosalotti srl
Via Ponte di Sotto, 31/A
33070 Brugnera PN
Italia
T +39 0434 624680
F +39 0434 624842
info@rigosalotti.it
www.rigosalotti.it

Rigosalotti srl

Via Ponte di Sotto, 31/A

33070 Brugnera PN

Italia

T +39 0434 624680

F +39 0434 624842

info@rigosalotti.it

www.rigosalotti.it